

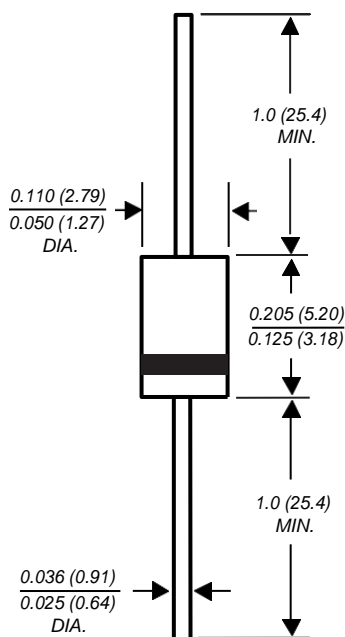

DO-204AM



Dimensions in inches and (millimeters)

### Features

- Silicon Power Zener Diodes.
- For use in stabilizing and clipping circuits with high power rating.
- The Zener voltages are graded according to the international E 24 standard. Smaller voltage tolerances are available upon request.

### Mechanical Data

**Case:** JEDEC DO-204AM molded plastic body

**Weight:** approx. 0.34g

**Packaging Codes/Options:**

E2/4K per Ammo mag. (52mm tape), 20K/box  
E3/5K per 13" reel (52mm tape), 10K/box

### Maximum Ratings and Thermal Characteristics (T<sub>A</sub> = 25°C unless otherwise noted)

Parameter	Symbol	Value	Unit
Zener Current (see Table "Characteristics")			
Power Dissipation at T <sub>amb</sub> = 25°C	P <sub>tot</sub>	2.0 <sup>(1)</sup>	W
Thermal Resistance Junction to Ambient Air	R <sub>θJA</sub>	60 <sup>(1)</sup>	°C/W
Junction Temperature	T <sub>j</sub>	150	°C
Storage Temperature Range	T <sub>s</sub>	-55 to +150	°C

**Note:**

(1) Valid provided that leads are kept at ambient temperature at a distance of 10mm from case.



### Electrical Characteristics (T<sub>J</sub> = 25°C unless otherwise noted)

Type	Zener voltage <sup>(2)</sup> at I <sub>ZT</sub> V <sub>Z</sub> (V)	Dynamic resistance at I <sub>ZT</sub> f = 1 kHz max r <sub>Zj</sub> (Ω)	Temp. coeff. of Zener volt. at I <sub>ZT</sub> α <sub>VZ</sub> (10 <sup>-4</sup> /K)	Test current I <sub>ZT</sub> (mA)	Reverse voltage at I <sub>R</sub> = 1 μA V <sub>R</sub> (V)	Admissible Zener current <sup>(1)</sup> at T <sub>amb</sub> = 25°C I <sub>Z</sub> (mA)
ZY1 <sup>(3)</sup>	0.71 ... 0.82	1	-26 ... -16	100	-	1000
ZY3.6	3.4 ... 3.8	7	-7 ... +2	100	-	440
ZY3.9	3.7 ... 4.1	7	-7 ... +2	100	-	410
ZY4.3	4.0 ... 4.6	7	-7 ... +3	100	-	360
ZY4.7	4.4 ... 5.0	7	-7 ... +4	100	-	330
ZY5.1	4.8 ... 5.4	5	-6 ... +5	100	-	300
ZY5.6	5.2 ... 6.0	2	-3 ... +5	100	> 1.5	275
ZY6.2	5.8 ... 6.6	2	-1 ... +6	100	> 1.5	245
ZY6.8	6.4 ... 7.2	2	0 ... +7	100	> 2	220
ZY7.5	7.0 ... 7.9	2	0 ... +7	100	> 2	200
ZY8.2	7.7 ... 8.7	2	+3 ... +8	100	> 3.5	180
ZY9.1	8.5 ... 9.6	4	+3 ... +8	50	> 7.4	165
ZY10	9.4 ... 10.6	4	+5 ... +9	50	> 8.2	145
ZY11	10.4 ... 11.6	7	+5 ... +10	50	> 9.2	135
ZY12	11.4 ... 12.7	7	+5 ... +10	50	> 10	120
ZY13	12.4 ... 14.1	10	+5 ... +10	50	> 10.7	110
ZY15	13.8 ... 15.8	10	+5 ... +10	50	> 12	98
ZY16	15.3 ... 17.1	15	+6 ... +11	25	> 13.3	90
ZY18	16.8 ... 19.1	15	+6 ... +11	25	> 14.7	80
ZY20	18.8 ... 21.2	15	+6 ... +11	25	> 16.5	72
ZY22	20.8 ... 23.3	15	+6 ... +11	25	> 18.3	66
ZY24	22.8 ... 25.6	15	+6 ... +11	25	> 20.1	60
ZY27	25.1 ... 28.9	15	+6 ... +11	25	> 22.5	53
ZY30	28 ... 32	15	+6 ... +11	25	> 25.1	48
ZY33	31 ... 35	15	+6 ... +11	25	> 27.8	44
ZY36	34 ... 38	40	+6 ... +11	10	> 30.2	40
ZY39	37 ... 41	40	+6 ... +11	10	> 32.9	37
ZY43	40 ... 46	45	+7 ... +12	10	> 35.6	33
ZY47	44 ... 50	45	+7 ... +12	10	> 39.2	30
ZY51	48 ... 54	60	+7 ... +12	10	> 42.8	27
ZY56	52 ... 60	60	+7 ... +12	10	> 47.3	25
ZY62	58 ... 66	80	+8 ... +13	10	> 51.7	21
ZY68	64 ... 72	80	+8 ... +13	10	> 57.1	20
ZY75	70 ... 79	100	+8 ... +13	10	> 63.2	18
ZY82	77 ... 88	100	+8 ... +13	10	> 68.6	16
ZY91	85 ... 96	200	+9 ... +13	5	> 75.7	15
ZY100	94 ... 106	200	+9 ... +13	5	> 83.7	13
ZY110	104 ... 116	250	+9 ... +13	5	> 92.6	12
ZY120	114 ... 127	250	+9 ... +13	5	> 101.6	11
ZY130	124 ... 141	300	+9 ... +13	5	> 110.5	10
ZY150	138 ... 156	300	+9 ... +13	5	> 123	9
ZY160	153 ... 171	350	+9 ... +13	5	> 136	8.5
ZY180	168 ... 191	350	+9 ... +13	5	> 149	8
ZY200	188 ... 212	350	+9 ... +13	5	> 167	7.5

**Notes:** (1) Valid provided that leads are kept at ambient temperature at a distance of 10 mm from case

(2) Tested with pulses t<sub>p</sub> = 5 ms

(3) The ZY1 is a silicon diode operated in forward direction. Hence, the index of all parameters ratings should be "F" instead of "Z". Connect the cathode lead to the negative pole



### Ratings and Characteristic Curves (T<sub>A</sub> = 25°C unless otherwise noted)

#### Breakdown characteristics

T<sub>j</sub> = constant (pulsed)

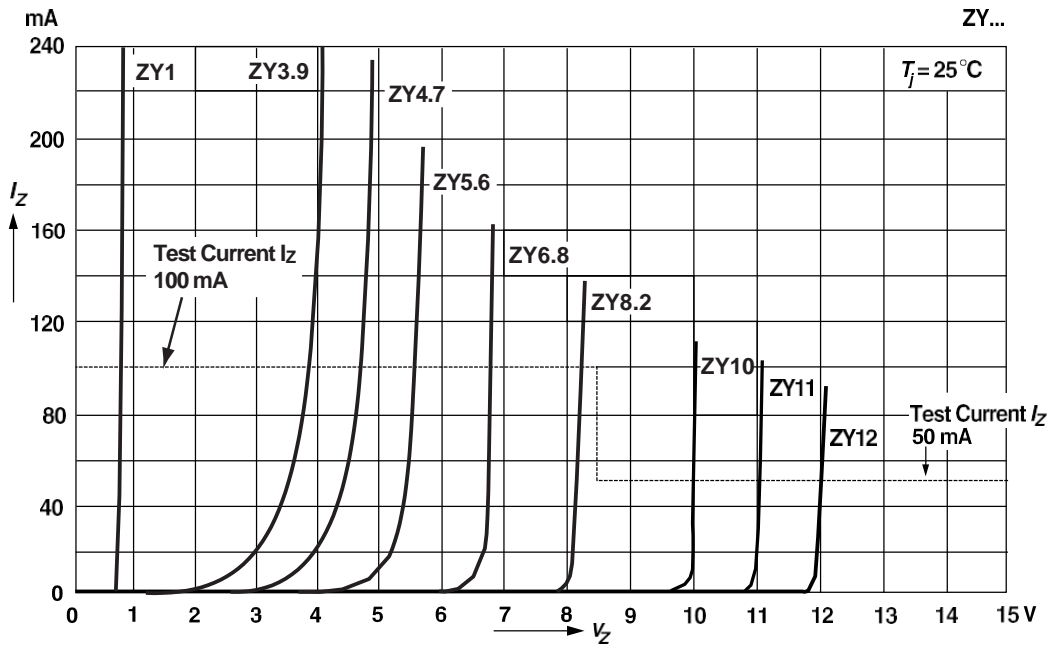

#### Breakdown characteristics

T<sub>j</sub> = constant (pulsed)

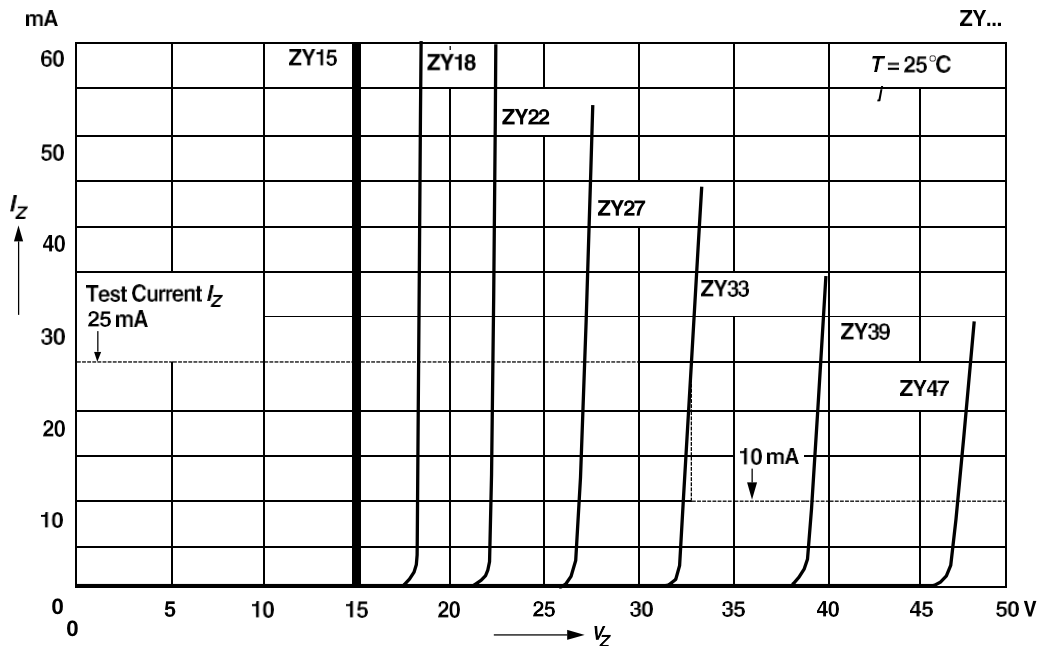

## Ratings and Characteristic Curves (T<sub>A</sub> = 25°C unless otherwise noted)

### Breakdown characteristics

T<sub>J</sub> = constant (pulsed)

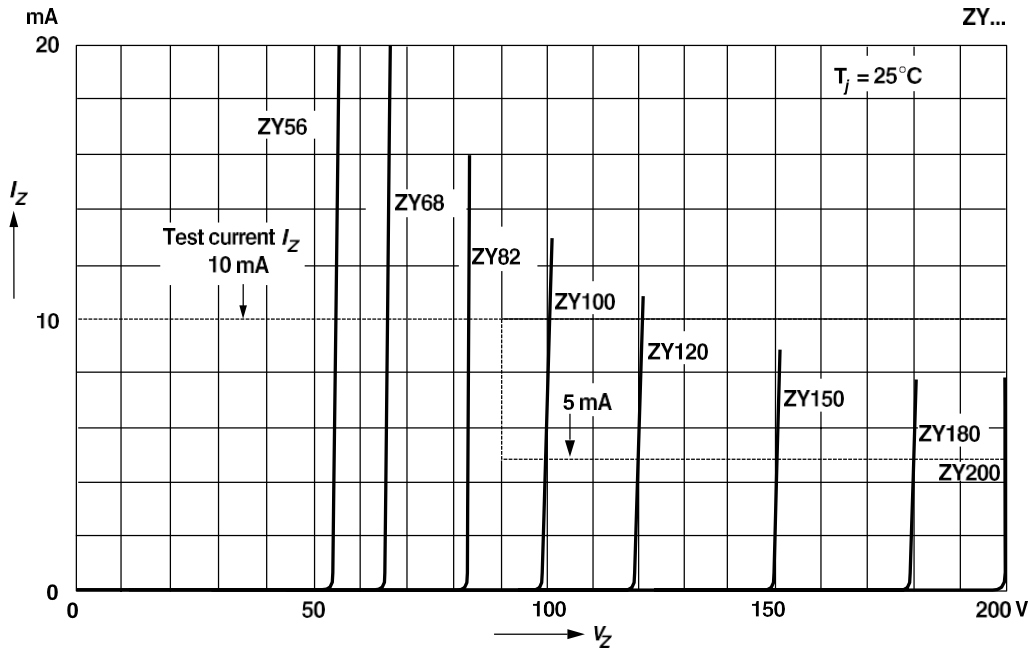

### Admissible power dissipation versus ambient temperature

Valid provided that leads are kept at ambient temperature at a distance of 10 mm from case

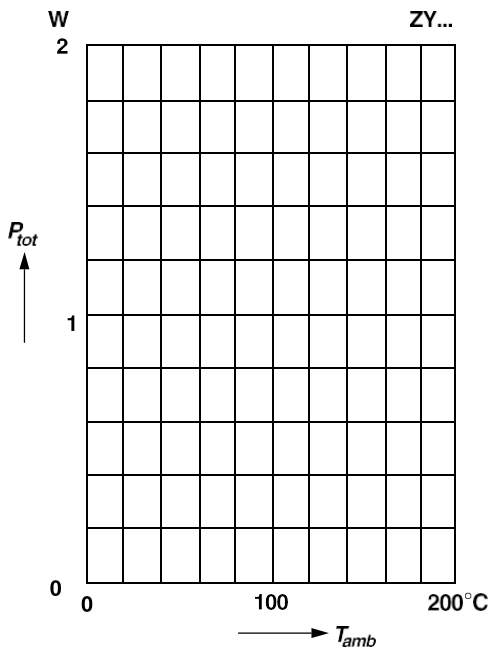

### Dynamic resistance versus Zener current

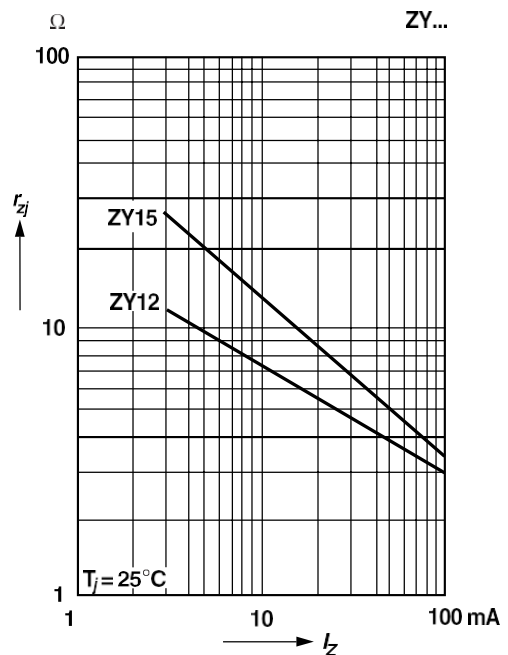

### Ratings and Characteristic Curves (T<sub>A</sub> = 25°C unless otherwise noted)

Dynamic resistance versus Zener current

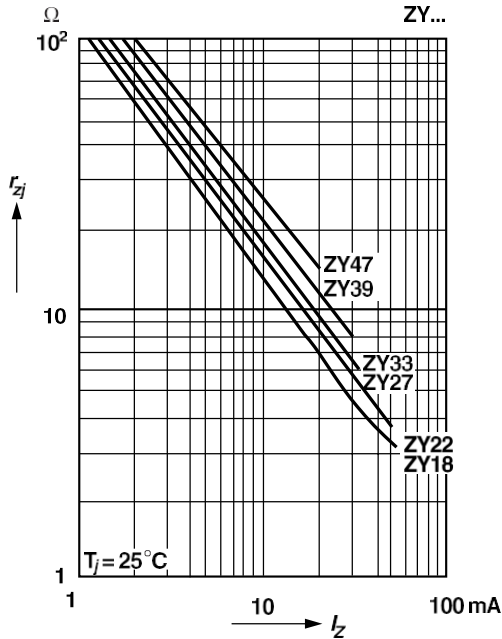

Thermal differential resistance versus Zener voltage

Valid provided that leads are kept at ambient temperature at a distance of 10 mm from case

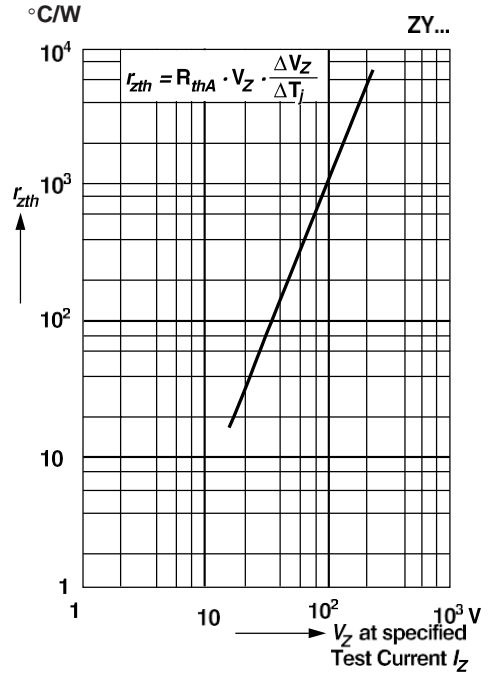

Dynamic resistance versus Zener current

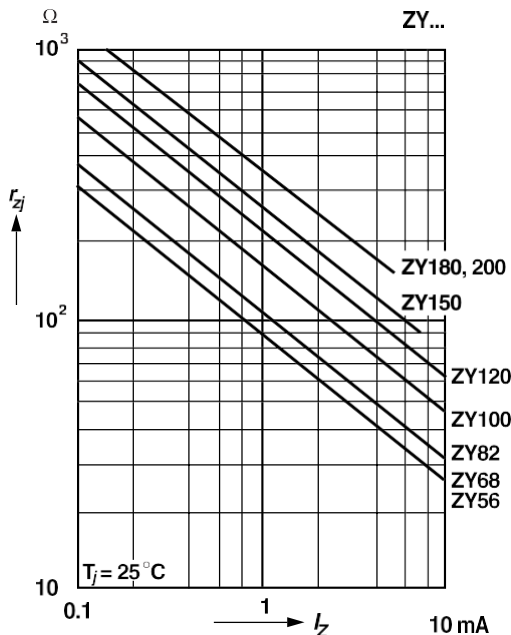

Change of Zener voltage from turn-on up to the point of thermal equilibrium versus Zener Voltage

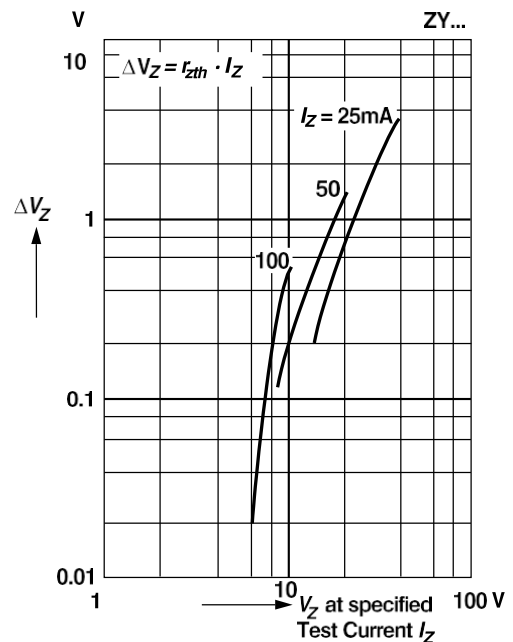

### Ratings and Characteristic Curves (T<sub>A</sub> = 25°C unless otherwise noted)

Relative change of Zener voltage versus turn-on time

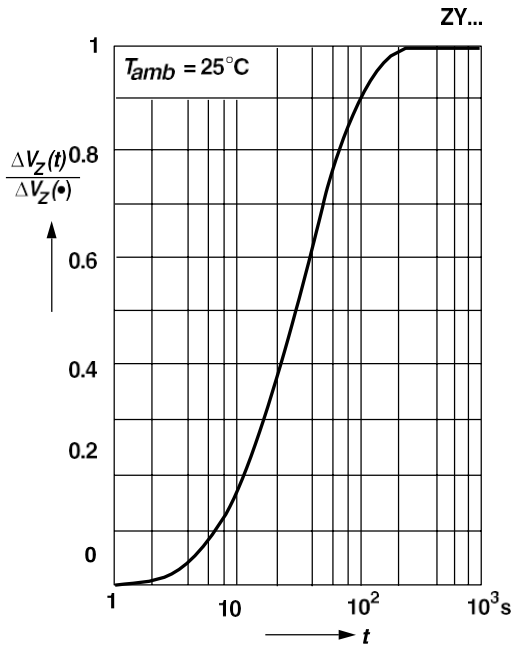

Thermal resistance versus lead length

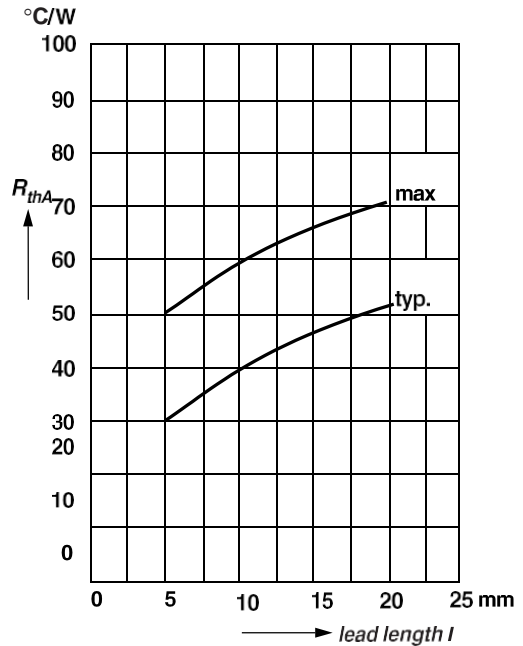

Pulse thermal resistance versus pulse duration

Valid provided that leads are kept at ambient temperature at a distance of 10 mm from case

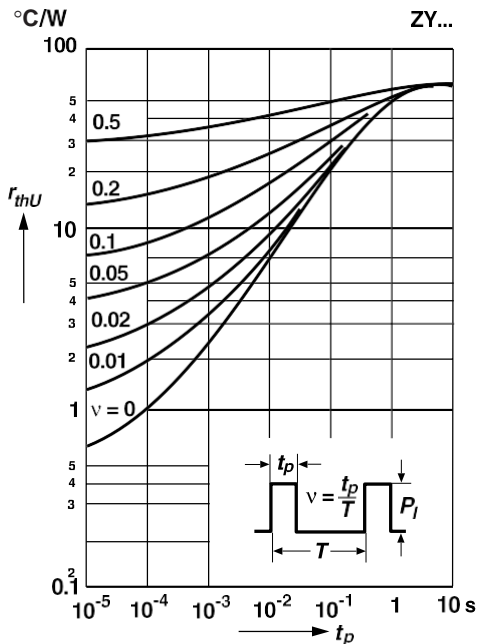

## Ratings and Characteristic Curves (T<sub>A</sub> = 25°C unless otherwise noted)

Difference between Zener voltage at test current pulses less than 1 s duration and Zener voltage at the point of thermal equilibrium versus Zener current

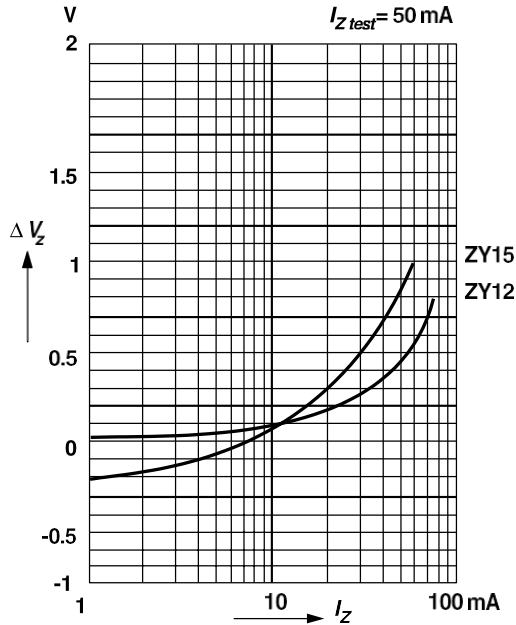

Difference between Zener voltage at test current pulses less than 1 s duration and Zener voltage at the point of thermal equilibrium versus Zener current

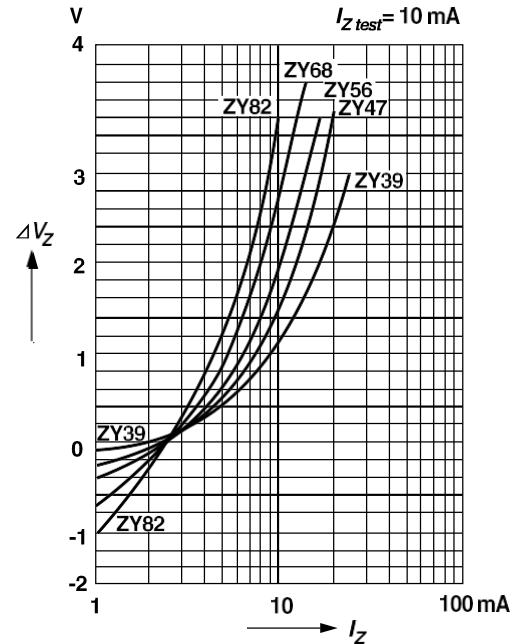

Difference between Zener voltage at test current pulses less than 1 s duration and Zener voltage at the point of thermal equilibrium versus Zener current

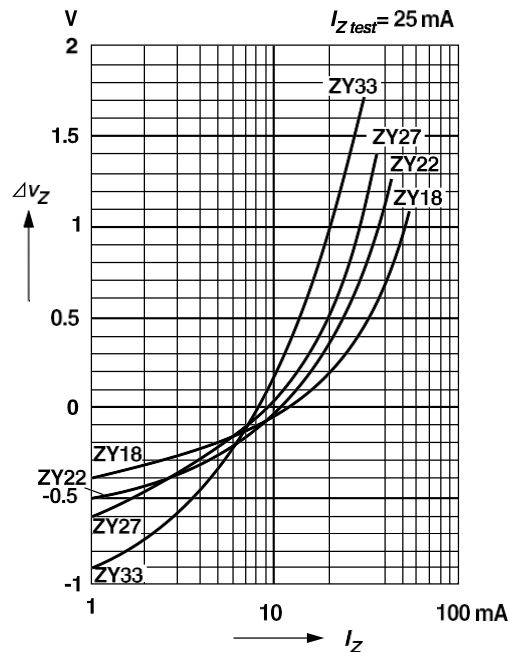

Difference between Zener voltage at test current pulses less than 1 s duration and Zener voltage at the point of thermal equilibrium versus Zener current

