



WEET Technology Company Limited

General Purpose Rectifiers

10A05 THRU 10A10

VOLTAGE RANGE

50 to 1000 Volts

CURRENT

6.0 Ampere

FEATURES

- Low forward voltage drop
- Low leakage current
- High forward surge capability
- High temperature soldering guaranteed
260°C/10 seconds, 0.375"(9.5mm) lead length at 5 lbs(2.3kg) tension

MECHANICAL DATA

- Case: Transfer molded plastic
- Epoxy: UL94V-0 rate flame retardant
- Polarity: Color band denotes cathode end
- Lead: Plated axial lead, solderable per MIL-STD-202E method 208C
- Mounting position: Any

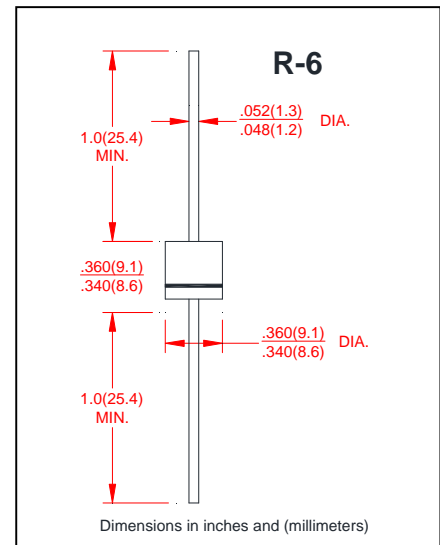

MAXIMUM RATINGS AND ELECTRICAL CHARACTERISTICS

- Ratings at 25°C ambient temperature unless otherwise specified
- Single Phase, half wave, 60Hz, resistive or inductive load
- For capacitive load derate current by 20%

	SYMBOLS	10A05	10A1	10A2	10A4	10A6	10A8	10A10	UNITS
Maximum Repetitive Peak Reverse Voltage	V_{RRM}	50	100	200	400	600	800	1000	Volts
Maximum RMS Voltage	V_{RMS}	35	70	140	280	420	560	700	Volts
Maximum DC Blocking Voltage	V_{DC}	50	100	200	400	600	800	1000	Volts
Maximum Average Forward Rectified Current(FIG.1) 0.375"(9.5mm) lead length at $T_A=60^\circ\text{C}$	$I_{(AV)}$	10							Amps
Peak Forward Surge Current 8.3ms single half sine-wave superimposed on rated load (JEDEC method)	I_{FSM}	300							Amps
Maximum Instantaneous Forward Voltage at 6.0A	V_F	1.1							Volts
Maximum DC Reverse Current at Rated DC Blocking Voltage	$T_A = 25^\circ\text{C}$	10							μA
	$T_A = 100^\circ\text{C}$	100							
Typical Junction Capacitance (NOTE 1)	C_J	150							pF
Typical Thermal Resistance (NOTE 2)	$R_{\theta JA}$	10							$^\circ\text{C}/\text{W}$
Operating and Storage Temperature Range	T_J, T_{STG}	-55 to +150							$^\circ\text{C}$

Notes:

1. Measured at 1.0MHz and applied reverse voltage of 4.0 Volts.
2. Thermal Resistance from Junction to Ambient at .375"(9.5mm) lead length, P.C. board mounted.



WEE Technology Company Limited

General Purpose Rectifiers

10A05 THRU 10A10

VOLTAGE RANGE 50 to 1000 Volts
CURRENT 6.0 Ampere

FIG.1-TYPICAL FORWARD CURRENT DERATING CURVE

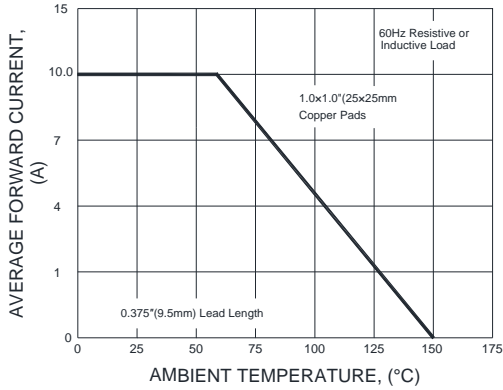

FIG.2-MAXIMUM NON-REPETITIVE PEAK FORWARD SURGE CURRENT

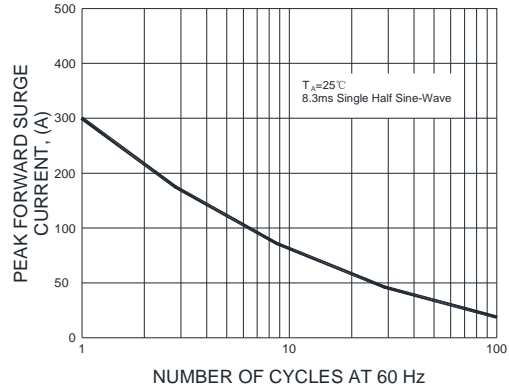

FIG.3-TYPICAL INSTANTANEOUS FORWARD CHARACTERISTICS

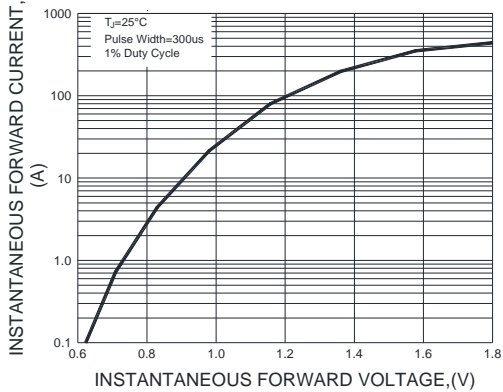

FIG.4-TYPICAL REVERSE CHARACTERISTICS

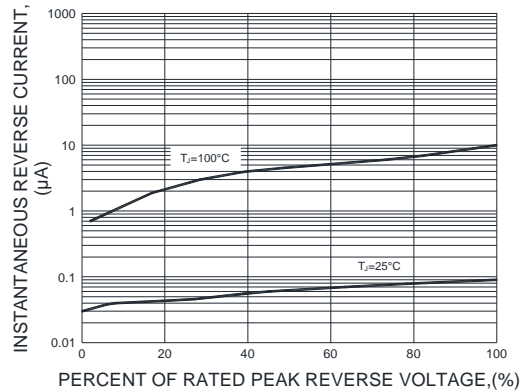
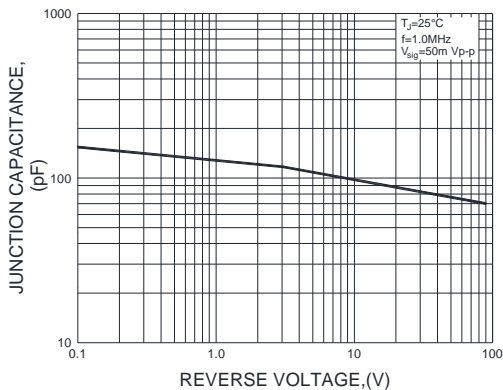

FIG.5-TYPICAL JUNCTION CAPACITANCE



Note: Specifications are subject to change without notice. For more detail and update, please visit our website.